

Coffee table 48"x 24"



1 - Tools and Material list

Tools for wood:

Table saw
miter saw / jig saw
Jointer
Planer
Router
Router table
Sander
Biscuit joiner
Drill or driver
Straight bit
Rabbeting bit
3/8" drill clamps
Mallet
Chalk
Leveling tool
Dust mask and safety glasses
Paint brush

Tools for metal:

Steel bender
Gloves
Welding machine and protection
Grinder
Cut off wheel
Chop Saw (for metal)
Screw gun/drill
Metal driving bit

Materials and cut list:

table top:

2" boards cut to 6" x 40", quantity: 4

2" boards cut to 4" x 24", quantity: 2

table stand:

2"x2" solid wood cut to 17" height, quantity: 4

square rubber base: 2" x 2" x 3/8", quantity: 4

nails and screws

degreaser

black spray and clear coat paint for metal

1/10" metal sheet cut to 2" x 4 1/10", quantity: 4

1/10" metal sheet cut to 1 1/4" x 22 3/4", quantity: 4

1/10" metal sheet cut to 1 1/4" x 1 1/4", quantity: 4

table base:

1 1/2" boards cut to 6" x 40", quantity: 4

1 1/2" boards cut to 4" x 24", quantity: 2

wood finish:

Fine grit sandpaper

Polyurethane

1- Preparing the lumber

if you use scraps of wood:

Choose a bit bigger sizes to have the right dimensions after milling and preparing the lumber.

Mill the lumber:

if the boards are warped, do this for step for each piece apart: keep a downward pressure to flatten both faces using a jig saw over a jointer.

Mill the boards at 2" thick

Rip to width, joint the edges straight and square using a table saw and cut to their final width of 6".

Place the boards on a flat surface and arrange for length trimming.

Any crook in the board should face down.

Square the ends and cut parts to length.

Work from long to short (to avoid cutting a piece too short.)

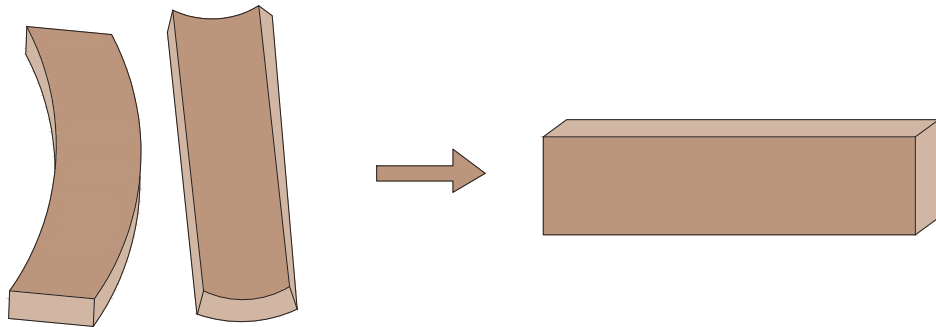

2 - Table top

Dimensions and quantities of lumber for the top are as below:

2" boards cut to 6" x 40", quantity: 4

2" boards cut to 4" x 24", quantity: 2

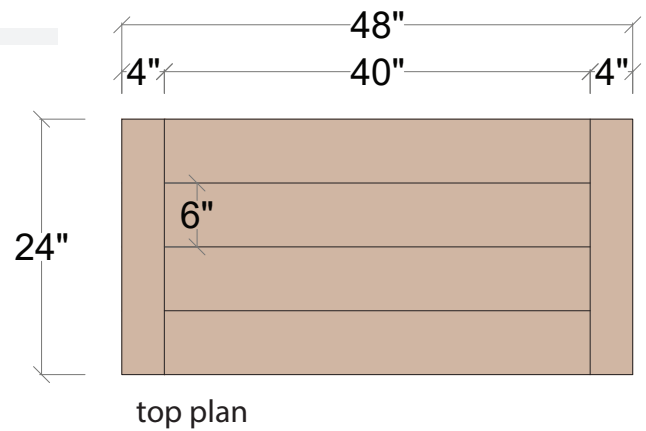

Use Biscuits for Alignment:

Make a tight mortise joint on each of the 2" sides of the lumber (every 8" apart).

Spread glue on each side of the boards, use clamping pressure and secure the lumber. Scrape glue excess then wait a few hours until dry.

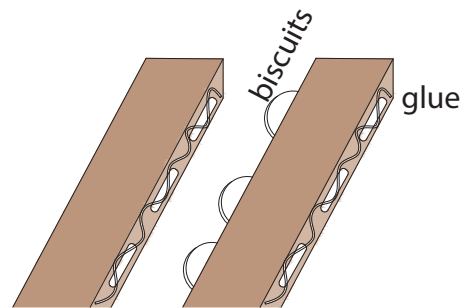

Prepare the breadbord ends for the stands using a rabbeting bit. Flip the boards over to make a rabbet on each end of the board. (as per detail A)

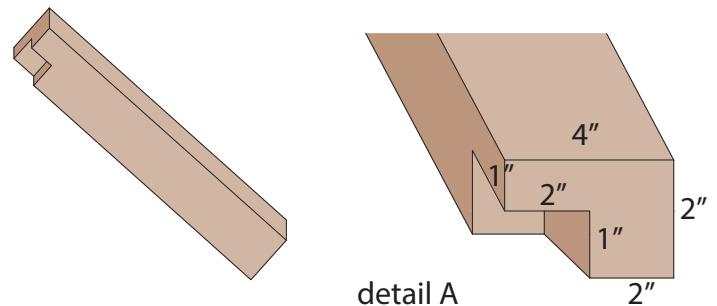

Make the breadbord ends using a rabbeting bit. Make a rabbet on each end and face of the board. This will give the top a long tenon. Spread glue on each side of the boards, use clamping pressure and secure the lumber. Scrape glue excess then wait a few hours until dry.

Tenon dimensions: 2" x 20" as per drawing

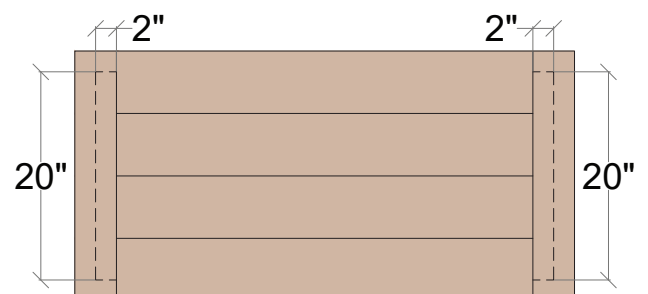
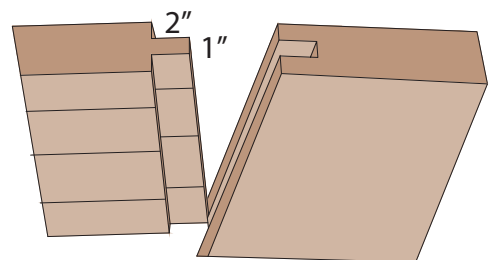

3 - Table stand wood work

Dimensions and quantities of lumber for the stand are as below:

3"x3" solid wood cut to 17" height, quantity: 4

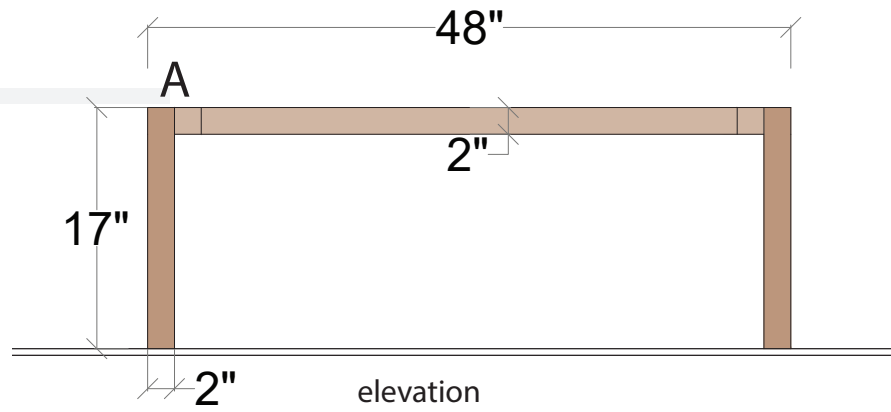

For the assembly to the top board:
Prepare the legs by making a rabbet on the top of each stand. (as per detail A)

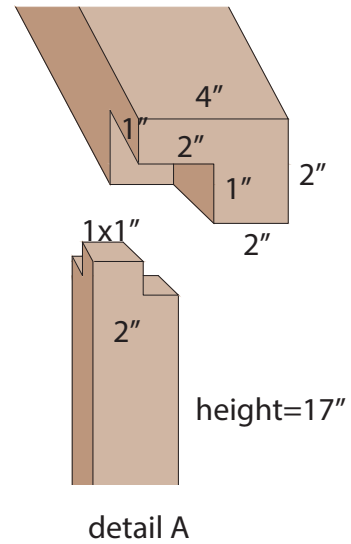

For the assembly to the base board:
Prepare the legs by making a rabbet on each stand at 4" height from the bottom. (as per detail C)

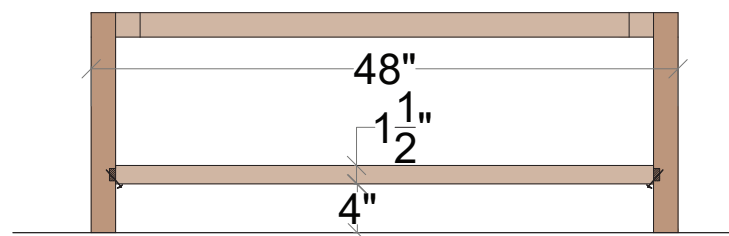
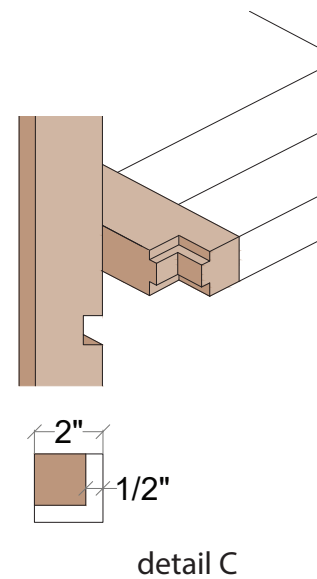

4.1 - Table base

Dimensions and quantities of lumber for the base are as below:

1 1/2" boards cut to 6" x 40", quantity: 4

1 1/2" boards cut to 4" x 24", quantity: 2

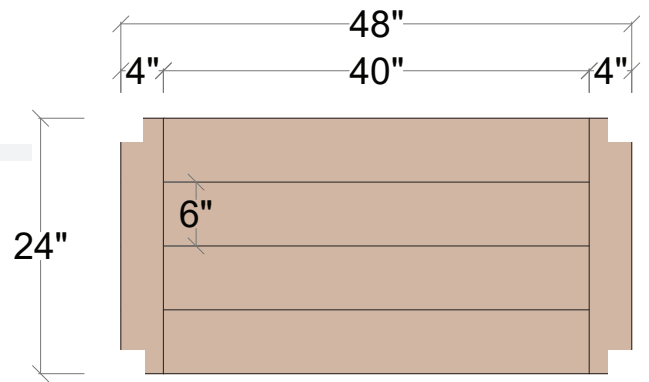

base plan

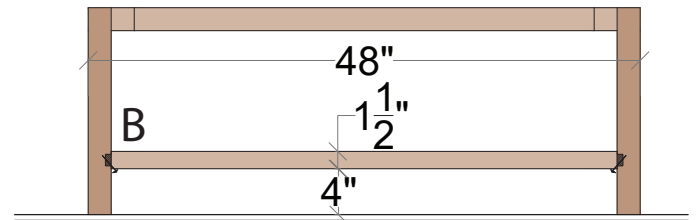

elevation

Use Biscuits for Alignment:

Make a tight mortise joint on each of the 2" sides of the lumber (every 8" apart).

Spread glue on each side of the boards, use clamping pressure and secure the lumber. Scrape glue excess then wait a few hours until dry.

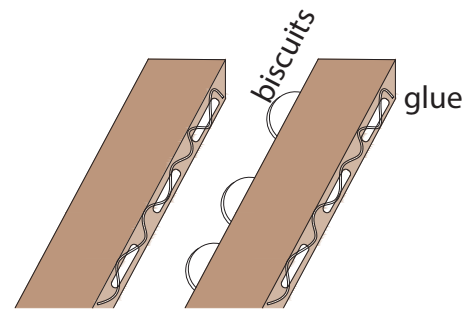

Prepare the breadbord ends: cut 1 1/2" x 1 1/2" from the outer side. Using a rabbeting bit, make a rabbet on each end (as per detail A). Flip the boards over to make a rabbet on each end of the board.

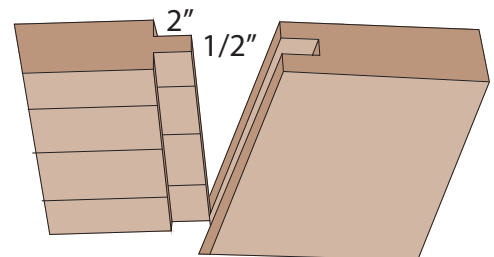

Tenon dimensions: 2" x 16" as per drawing

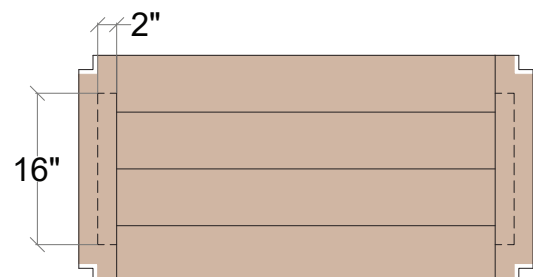

4.2 - Table base

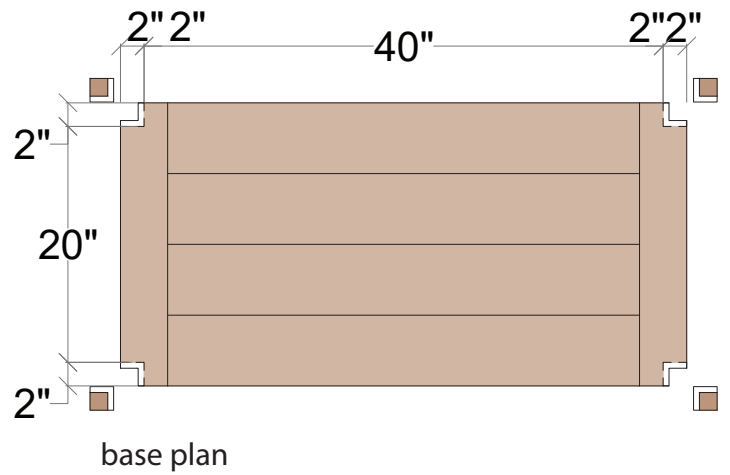

For the assembly to the stands:
Prepare the base board by making a 1/2" rabbet on each
end of each face. (as per detail C)

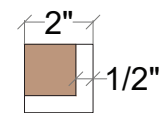
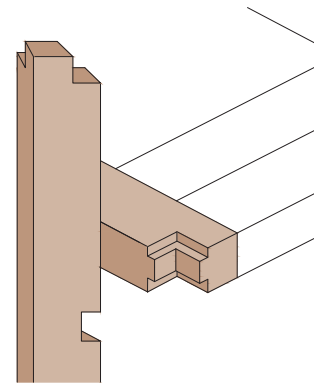

detail C

5 - Assemble and finish the wood

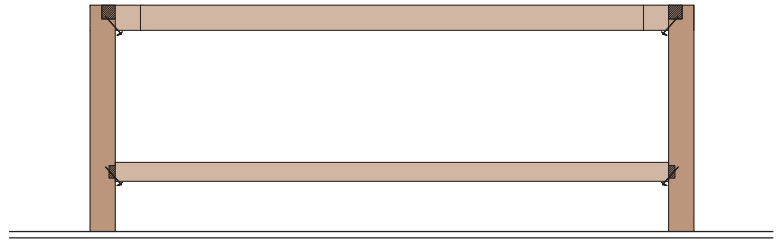

Assemble the top to the stand using nails and glue

Level the table legs:

Hold your table on a work surface so the four legs are on the ground.

Check that the surface is flat by using a leveling tool.

If the table is not levelled, measure the length between the ground and any legs that are off the ground, cut off a piece of cork that matches the length of the difference and stick it to the bottom of the leg that is shorter using hot glue.

Assemble the base to the stand using nails and glue and level the table again.

Use a fine grit sandpaper to sand the wood.

Apply polyurethane (or linseed oil for indoor furniture, or a finish of your choice) to the entire piece. Apply 3 coats with 20 minutes in between, in light and even coats, always brushing with the grain.

Install rubber base at the bottom of the wood stands.
square rubber base: 3" x 3" x 3/8", quantity: 4



6 - Steel work

Buy and cut the steel using the dimensions of the cuts below:

1/10" metal sheet cut to 2" x 4 1/10", quantity: 4

1/10" metal sheet cut to 1 1/4" x 22 3/4", quantity: 4

1/10" metal sheet cut to 1 1/4" x 1 1/4", quantity: 4

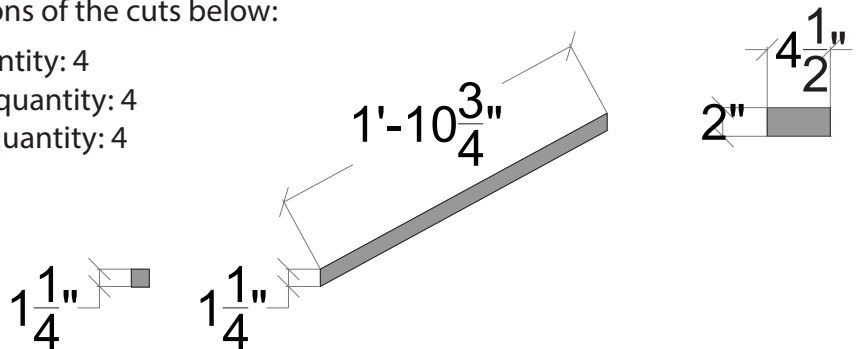

Make sure to clean off all your cuts with a grinder.

Bend your 2" x 4 1/10" Steel sheets to have nice and clean 90 degree corners. Drill holes in metal. Use oil for lubrication.

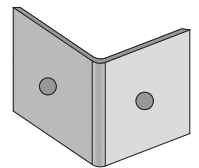

Weld the steel then clean up and smooth out any slag with a grinder.

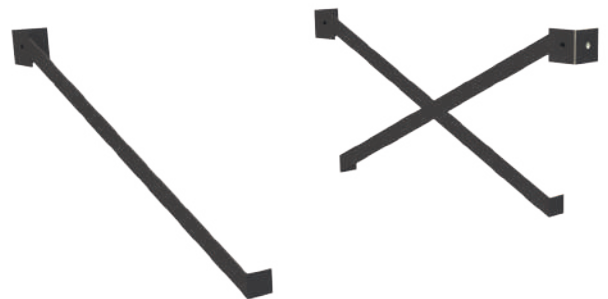

Paint the metal with black spray, then use a clear coat to seal it.

You can use an extra fine steel wool to rough up painted finish and give it a nice rustic look.

Drill holes in the wood.

Position the metal into an X shape, mark the center of the metal for drilling.

Assemble the metal into on the wood and secure the X shape with a screw.

